

N-TRAK Joiner Track Measuring Gage



Above is a picture of an easy-to-make gage that greatly reduced the amount of time it takes us to install joiner tracks at NTrak meets. We have been using it now for almost a year and it has proven to be very reliable and easy to use.

To build your own gage, all you need is a composite digital caliper, some small hardwood pieces, 4 small screws and some type of adhesive that will adhere to the wood and composite material of the caliper. I used scrap pieces of oak, #0 pan head screws and JB Weld. The two important things to shoot for are: the distance from the face of one hardwood block to the face of the other underneath the caliper readout, and to keep these faces as parallel as possible. I made this dimension 1.015", which gives a gap of about .007" at each end of the track. It also allows the simple math calculation to determine the correct length of joiner track to use.

The composite digital calipers can be purchased at Harbor Freight, a tool surplus store, at times under \$10. To prepare the caliper for adding the gaging blocks, simply cut off the jaws and file the raised area down to the level of the jaws per the following drawing. When cutting the jaws away, leave a small (approx. 1/16") section of the original jaw mating surfaces to make sure the jaws return to zero each time they are fully closed.

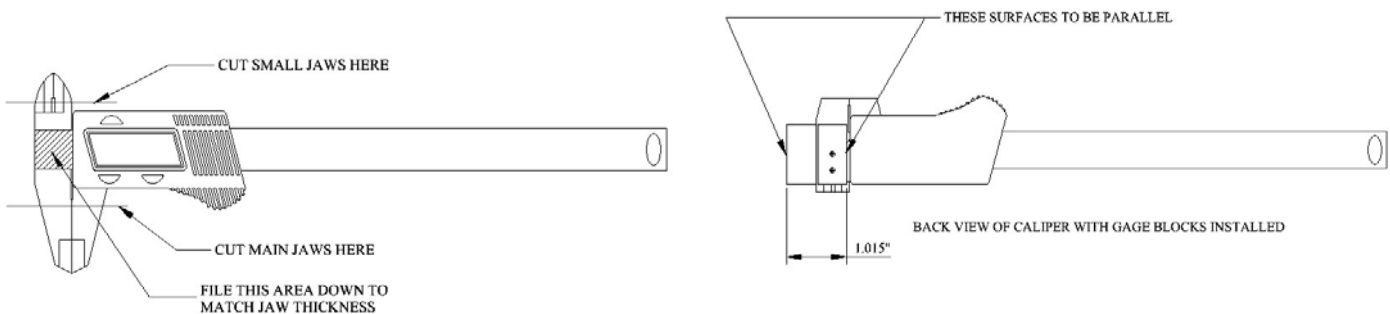

The width of the wooden gage blocks should be around 1". The following pictures show the geometry and location of the gage blocks.

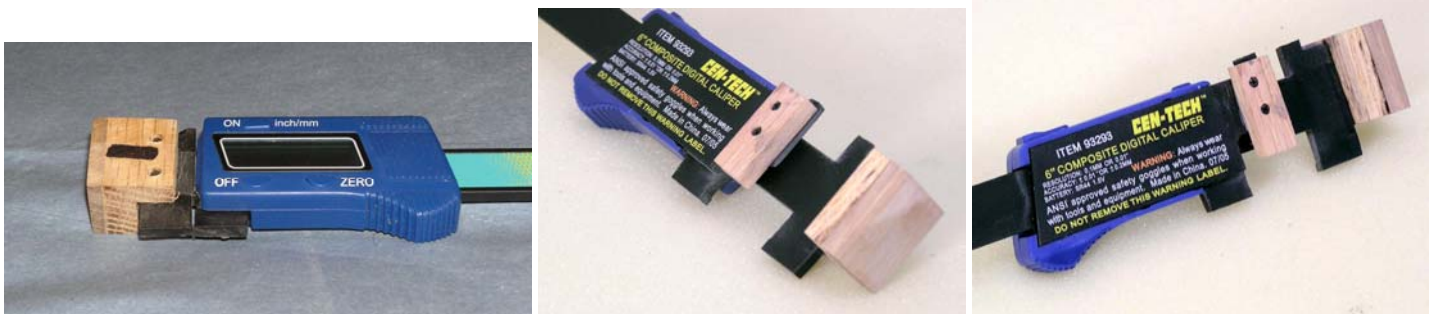

N-TRAK Joiner Track Measuring Gage

The screw holes in the caliper were drilled a little undersized so the screws cut threads in the caliper. The screw holes in the wood blocks were drilled a little oversize to allow a bit of adjustment in aligning the wood block faces for parallelism. The adhesive makes sure nothing moves after all is set. The screw length depends on the thickness of your wood blocks. Just make sure the screw heads are recessed so they do not interfere with measuring. Also make sure they do not protrude through the opposite side of the caliper jaws. Buy extra batteries. The ones that come with the low buck calipers can die quickly.

USING THE GAGE:

This gage is sensitive to electric current and CAN NOT be used with power on to the tracks. The induced electric current will cause the gage to malfunction.

To accurately measure the joiner track gap, first turn on the gage, make sure it is reading inches. Zero the gage per the instructions that came with it. Lay the gage in the gap between track ends and open the jaws until the wood block faces contact the rail ends. Very important!--- Make sure they are hitting just the rail ends, not rail joiners left in from the last layout, errant ballast, or anything else. Read the measurement from the digital readout and add exactly 1 inch. For joiner tracks where insulated joiners are going to be used, instead of exactly 1 inch, add .980 inch.

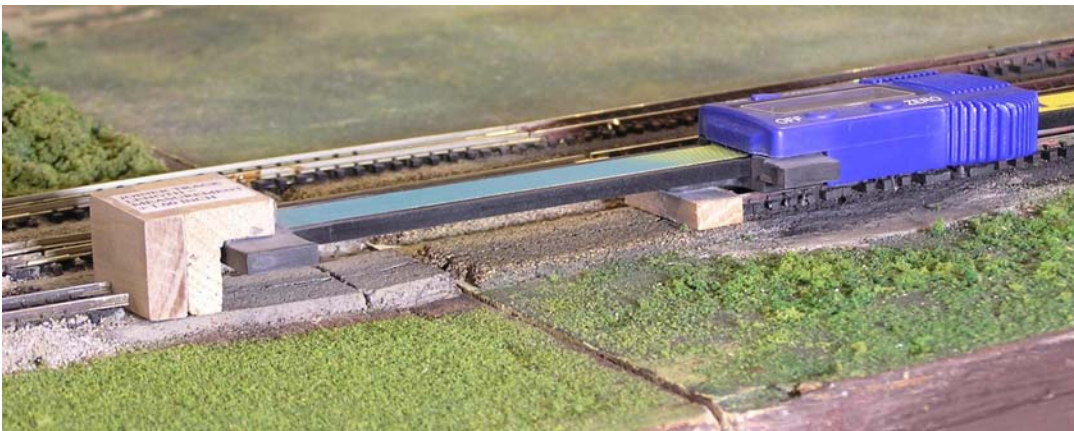

At layout setup, we use a four man team. The gage man would measure the gap, add the appropriate amount and call out the track length. The track box man would pick out the appropriate sized joiner track and drop it in the gap. A two man crew would come behind putting rail joiners on the joiner tracks and install them in the gap they had been dropped in. If you don't have the exact length, then you can use a joiner track .010 to .020 shorter. Just remember, the shorter the track, the larger the gaps.

This is one of those things that takes much longer to explain than do. Once you get used to using the gage, the number callout will become second nature.